



# Visitability

An Inclusive Design Approach for Housing

This booklet provides a summary of the goals, benefits, and features of inclusive housing design. It is a preview of a forthcoming book entitled *Inclusive Housing: A Pattern Book*. Excerpts from the book along with an annotated version of the new ICC/ANSI A117.1 Type C visitability standards will give you a better understanding of what visitability is and why it is important to housing design.

THE CENTER FOR INCLUSIVE DESIGN AND ENVIRONMENTAL ACCESS (IDEA)



MIZNER PARK

## Visitability and Neighborliness

The goal of inclusive design is to make buildings and communities more livable for all types of people. Inclusive design should embrace other good design goals and reinforce them, not work against them. Five of the most important are sustainability, marketability, affordability, security, and social interaction.

In this booklet, and the book, we demonstrate how accessible design can be compatible with these goals and, in fact, is an essential aspect of neighborliness.

### Visitability

Visitability represents a highly focused strategy in the continuing evolution of accessible housing policy and practice in the United States. It is an affordable and sustainable approach for integrating basic accessibility features as a routine construction practice in all newly built 1-3 family homes.

As it was originally conceived, visitability seeks to make homes more accessible by having them meet only three conditions:

- One zero-step entrance at the front, side or rear of the home;

- 32 inch wide clearances at doorways and hallways with at least 36 inches of clear width;
- And, at least an accessible half bath on the main floor.

These features are considered the most essential for a person with mobility impairments to visit or live in a home, at least temporarily.

While many designers agree that accessibility can be easily incorporated in typical suburban housing, there is a need to show how it can be just as easily included in urban housing, traditional neighborhood designs and various contexts.

### Visitability Supports Neighborliness

**Inclusive housing design and urbanism are complementary.**

1. Urban housing is, by its nature, more dense than sprawling suburban subdivisions; thus, it increases social interaction opportunities for residents.
2. Higher density combined with mixed-use zoning reduces the distance residents must travel to conduct their daily activities.



NEIGHBORHOOD CHARACTER

This photo shows a mews, a feature that promotes friendship formation. But, without accessibility from houses to the mews, residents with mobility limitations cannot benefit from this feature.

3. Many people with certain physical, sensory, or cognitive conditions cannot drive. Reduced travel distances make environmentally friendly, accessible modes of transportation, rather than private automobiles, more feasible.
4. Providing accessible dwellings reduces the need for residents to renovate existing homes or move to new ones if they become disabled, conserving energy and materials, and preserving social networks.

For decades, urbanists have promoted the use of traditional house forms with the barriers of steps at all entrances, narrow interior doors, and tiny bathrooms. When considering housing for elderly or disabled people, urbanists have suggested that these two groups be provided specific housing types, e.g. flats and elevator buildings. They have rarely adopted inclusive design for ALL housing types, which facilitates remaining in one's home if disability occurs and aging in place. On the other hand, designers with expertise in accessible home design have neglected the importance of block and lot design, and have tended to view the individual house as the focus of accessible design. Access has to be provided in different ways to fit with the house and lot forms used at each level of



A HIGH-END ACCESSIBLE SUBURBAN HOME

This photo shows a high-end accessible suburban home with a zero-step front entry. When compared to homes with lengthy ramps in their front yards, this house style fits well in the suburban neighborhood.

density. In an urban area, in particular, the design of the block and lots, including finished grading, street, and walkway design, will play a much greater role in accessible design than it does in suburban and rural areas.

### **Inclusive urban housing increases marketability.**

Accessibility should contribute to meeting marketing goals (i.e. an appealing style that fits with the neighborhood and achieves desirable density) by helping to create communities that attract a broader market and remain viable for generations. If accessibility is designed in a way that impedes marketability then it will not be embraced by developers and designers. In fact, it will be actively resisted. On the other hand, if good examples are available, they can help counter preconceptions, demonstrate good design approaches, and be attractive to a wider segment of the population.

### **Inclusive urban housing does not preclude affordability.**

To ensure diversity at the community level, affordable housing for low and moderate-income



AN AFFORDABLE ACCESSIBLE SUBURBAN HOME

homebuyers needs to be incorporated in community plans. To keep a house affordable, new features can only be added. Thus, affordable housing advocates are concerned that accessible design will reduce the quantity and quality of affordable housing built in a community.

There are many ways to ensure that affordability, quality, and accessibility co-exist in inclusive housing. Efficient space planning, careful value engineering, and selection of low cost construction methods and details make visitability entirely compatible with affordability. In fact, inclusive design features have the potential to add value to affordable homes. For example, adding a half bath on the first floor of a home increases its value. As long as the additional cost is within the means of a homebuyer or tenant, then it is not a liability, it is an asset.

Fortunately, research and practice have demonstrated that there is no need to increase the size of a dwelling unit to provide basic accessibility. In high-density urban settings with traditional house forms, well-designed access in new construction eliminates the need to build expensive, unattractive long ramps or lifts when a resident becomes disabled. Planning the block carefully and following a few basic guidelines in home and lot design can make accessibility affordable.



LOW WALLS MAINTAIN PRIVACY GOALS

### Inclusive urban housing supports security concerns and ensures sufficient social interaction.

Many Urbanists have argued that an essential design feature needed to ensure social interaction and privacy is “semi-private” space, especially porches or landings raised at least 48 inches [1220 mm] above grade. They have maintained that height above the sidewalk increases the residents’ ability to maintain surveillance of the street. Unfortunately, this practice has resulted in many houses that do not permit aging in place or visits from people with mobility impairments. To address this problem, in 2009 some New Urbanist leaders initiated removal of the prescribed height and substituted descriptive language directing designers to achieve “appropriate private frontage.”

Privacy and security need not conflict with providing a zero-step entrance. It is important to note that careful design often can provide access at a rear or side entry while maintaining a raised front porch. If the zero step entrance is in fact located in front, there are many other ways to maintain privacy and security while ensuring sufficient social contact to promote friendship formation. A larger vocabulary of forms can be used to reach the same goals without introducing barriers to accessibility. These may include strategic use of landscape, low walls, fences, and other methods.



SHARED SEMI-PRIVATE SPACE MARKS TERRITORY



PLANTINGS CREATING PRIVACY

## Visitable Home Design and Beyond



ELEVATION OF A VISITABLE HOME

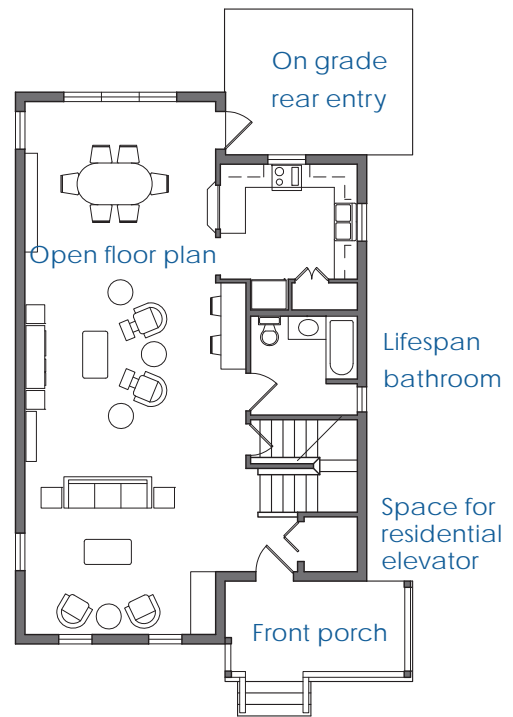

PLAN OF A VISITABLE HOME

This is an example of a single-family home design that includes visitable features. It has an on-grade rear entry and patio, a front porch accessible from the interior, an open plan, and a first floor bathroom. The bathroom has a 36-inch door and enough space for convenient wheelchair use. The plan also has additional features that support aging in place. The U-shaped kitchen reduces effort for all users. The house has space for a future residential elevator and a fully accessible second

storey. The open floor plan allows residents to use the living space in many ways. In fact, a sleeping space can be provided where the dining furniture is located in the illustrated plan. This plan is an example of “Lifespan Design,” another inclusive design strategy.

For many more housing plans & designs, see *Inclusive Housing: A Pattern Book*



ALLEY PROVIDES REAR OR SIDE ENTRY

## Visitability Standards

The rest of this booklet provides a summary of the requirements for visitable dwelling units in ICC/ANSI A117.1 (2009). The ICC/ANSI A117.1 Standard on Accessible and Usable Buildings and Facilities is the consensus standard in the U.S. for defining the details of accessible construction and is referenced by most building codes in the country. In 2008 the ICC committee that develops the A117 Standard developed a new section with technical design criteria for visitability based on a document developed by disability rights advocates for the Inclusive Home Design Act. Referred to as Type C units, the section can be referenced by future visitability laws and programs, thus promoting uniformity and aiding in their interpretation.

Since the standards are developed for use in a legal context, they include many provisions that heretofore have not been included in previous visitability laws to address potential problems with enforcement. For example, one of the issues that needed to be addressed was to clarify what minimum facilities in the home have to be on the accessible level, e.g. kitchen equipment, amount of living space, etc.

This document includes a summary of the Type C (visitable) requirements. Numbers following headings correspond to sections in the standard. Please note that the requirements of the standard are simplified here to provide a concise and easy to understand list of features. In particular, only the key cross-references to other parts of the Standard have been included. Consult the Standard for the actual wording and more detailed information\*.

\* Note: The IDEA Center does not warrant the completeness or accuracy of this document nor how it may be interpreted by building or planning officials.

## ICC Type C Units

While the concept of visitability puts a high priority on a zero step entrance, wide interior clearances, and an accessible bathroom, most visitability laws have included a few additional features. Similarly, the Type C units contain technical criteria for six features: no-step entrances, wider doorways, access to a half-bath on the main floor, reinforcement in bathroom walls for future grab bar installation, maneuvering space in food preparation facilities if provided on the floor served by the zero step entrance, and light switches and electrical outlets within comfortable reach for all.

## Unit Entrance (1006.2)

At least one unit entrance shall be on a circulation path complying with Section 1006.5 (Circulation Path) from a public street or sidewalk, a dwelling unit driveway, or a garage.

## Connected & Interior Spaces (1006.3 & 1006.4)

A circulation path complying with Section 1006.5 (Circulation Path) shall connect the unit entrance located on the circulation path to the following spaces:

- An entrance level toilet room or bathroom complying with Section 1006.6 (Toilet Room or Bathroom).
- One additional habitable space with an area 70 square feet [6.5 sq. m] minimum.
- When provided on the entrance level, a food preparation area complying with Section 1006.7 (Food Preparation Areas).

*Exception: A toilet room or bathroom shall not be required in units with less than 120 square feet [11 sq. m] of habitable space on the entrance level.*

## Circulation Path (1006.5)

**Components (1006.5.1):** The circulation path shall include one or more of the following elements: Walking surfaces with a slope not steeper than 1:20, doors and doorways, ramps, compliant elevators (Section 407-409), and compliant platform lifts (Section 410).

**Walking Surfaces (1006.5.2) and Thresholds (1006.5.3.2):** Thresholds and slopes not steeper than 1:20 shall comply with Section 303 (Changes in Level). Section 303.2 permits abrupt changes in level up to ¼ in. [6.4 mm]. Section 303.3 states, “Changes in level greater than ¼ in. [6.4 mm] in height and less than ½ in. [13 mm] maximum in height shall be beveled with a slope no greater than 1:2. Changes in level greater than ½ in. [13 mm] in height shall be ramped and comply with Section 405 (Ramps) or 406 (Curb Ramps).”

*Exception: Thresholds at exterior sliding doors shall be permitted to be ¾ inch [19 mm] maximum in height, provided they are beveled with a slope not steeper than 1:2.*

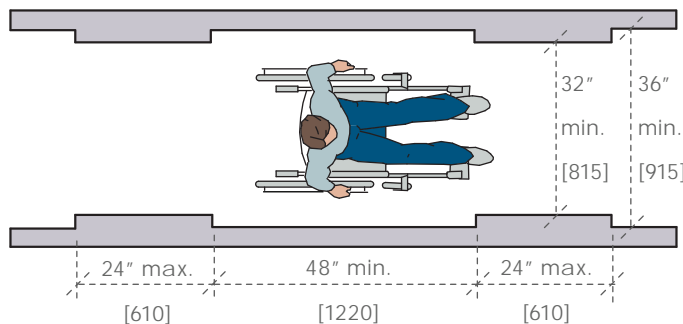

### WALKING SURFACES CLEAR WIDTH

Hallways and corridors are at least 36 in. clear with allowable pinch points of 32 in. clear width for no longer than 24 inches.

**Clear Width (1006.5.2.1):** The clear width of the circulation path shall comply with Section 403.5 (Clear Width) which states, hallways and corridors must have at least 36 in. [915 mm] clear width.

*Exception: Pinch points (short, narrower areas) are allowed to be 32 in. [815 mm] clear for a distance of 24 in. [610 mm] maximum (see figure).*

**Doors and Doorways (1006.5.3.1):** Swinging doors shall have a clear opening of 31 3/4 in. [810 mm] minimum measured from the jamb to the inside face of the door and stop with the door open at 90 degrees. Sliding and folding doors shall be measured from the jamb to the inside edge of the door in the open position. Automated doors may be used if they meet all applicable code requirements, including the requirements in ICC/ANSI A117.1.

*Exception: Doorways to closets with 15 SF [1.4 sq. m] space maximum.*

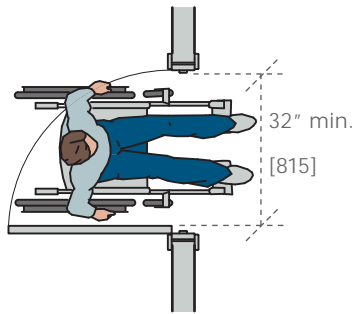

VISITABLE HINGED DOOR

Hinged doors – 31 3/4 in. min. clear width measured from the jamb to the inside face of the door when held open at 90 degrees.

**Ramps (1006.5.4):** Ramps shall comply with Section 405 (Ramps).

*Exception: Handrails, intermediate landings and edge protection are not required where the sides of ramp runs have a vertical drop-off of 1/2 inch [13 mm] maximum within 10 inches [255 mm] horizontally of a ramp run.*

**Toilet Room or Bathroom (1006.6)**

Toilet rooms or bathrooms covered by Section 1006.4 (Interior Spaces) shall include the following features:

- a. A lavatory and a toilet.
- b. Reinforcement and space clearances for the future installation of grab bars at toilets.

*Note: If more than one bathroom is provided on the entry floor, reinforcement is required in at least one full bathroom on that floor.*

- c. The wall reinforced for the future installation of grab bars shall be 18 inches [455 mm] from the centerline of the toilet.
- d. Lavatories must be at least 15 inches [380 mm] from the centerline of the toilet.
- e. Space clearances at the toilet must meet or exceed the minimum requirements for at least one of the following sections:

**“Parallel Approach” (1004.11.3.1.2.1):**

- i. Measured from the wall behind the toilet, there shall be a minimum clear space of 56 inches [1420 mm].
- ii. Measured from the wall designated for the future installation of grab bars, there shall be a minimum clear space of 48 inches [1220 mm].
- iii. Vanities or lavatories beside the toilet may overlap required space clearances.

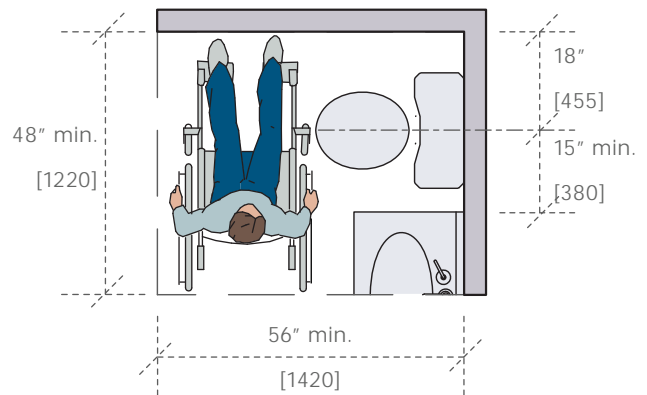

PARALLEL APPROACH

### “Forward Approach” (1004.11.3.1.2.2):

- i. Measured from the wall behind the toilet, there shall be a minimum clear space of 66 inches [1680 mm].
- ii. Measured from the wall designated for the future installation of grab bars, there shall be a minimum clear space of 48 inches [1220 mm].
- iii. Vanities or lavatories beside the toilet may overlap required space clearances.

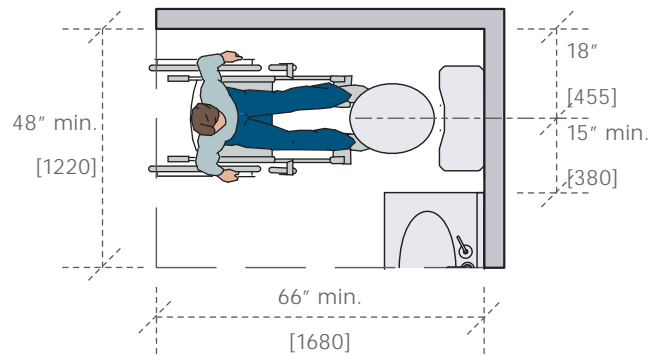

FORWARD APPROACH

### “Parallel or Forward Approach” (1004.11.3.1.2.3):

- i. Measured from the wall behind the toilet, there shall be a minimum clear space of 56 inches [1420 mm].
- ii. Measured from the centerline of the toilet, there shall be a minimum clear space of 42 inches [1065 mm].

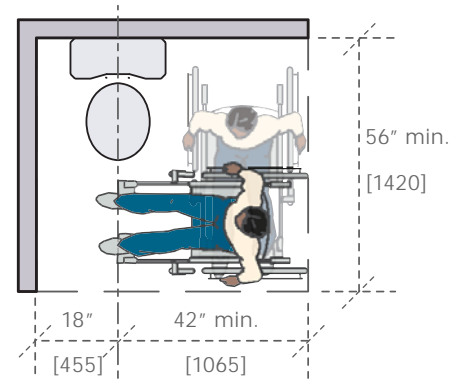

PARALLEL OR FORWARD APPROACH

## Food Preparation Areas (1006.7)

- a. When provided on the entrance level, the food preparation area shall include a sink, a cooking appliance, and a refrigerator.
- b. Clearances between all opposing base cabinets, counter tops, appliances or walls within the food preparation area shall be 40 inches [1015 mm] minimum.

*Exception: Spaces that do not have a cook-top or conventional range shall be permitted to have a minimum clearance of 36 inches [915 mm] wide.*

## Lighting Controls & Receptacle Outlets (1006.8)

The centerline of receptacle outlets and operable parts of lighting controls located a minimum of 15 inches [380 mm] and a maximum of 48 inches [1220 mm] above the finished floor.

*Exception: The following shall not be required to comply with Section 1006.8:*

1. Receptacle outlets serving a dedicated use (e.g. outlets intended for refrigerators or laundry equipment).
2. Controls mounted on ceiling fans and ceiling lights
3. Floor receptacle outlets
4. Lighting controls and receptacle outlets over countertops

This booklet includes excerpts from the forthcoming book:

## **Inclusive Housing: A Pattern Book** by Edward Steinfeld & Jonathan White

This book is a resource for designing communities to accommodate social diversity and provide equitable opportunities for all residents, or, inclusive design. It focuses on design of housing to provide accessibility to people with disabilities and, aging in place, while increasing convenience and safety for all residents. This book is one small effort toward affecting a change in design practices. This is the heart of the inclusive design idea – to transform the perception of difference as something about “them” to an understanding that design for diversity benefits all of us.

***Inclusive Housing: A Pattern Book* will be available for purchase in Fall of 2009. Watch our website for an announcement on the exact release date.**

---

**Concrete Change** is the organization that brought the concept of visitability to the U.S. and assists communities and professionals seeking to introduce visitability laws. For additional information on visitability, see Concrete Change at [www.concretechange.org](http://www.concretechange.org) or call +1 (404) 378.7455.

**The American Association of Retired People (AARP)** has taken a leadership role in promoting design for aging in place. They recently published a white paper on visitability, written by the IDEA Center and Concrete Change available at [http://www.aarp.org/research/housing-mobility/accessibility/2008\\_14\\_access.html](http://www.aarp.org/research/housing-mobility/accessibility/2008_14_access.html). See [www.aarp.org/research/housing-mobility](http://www.aarp.org/research/housing-mobility), or call +1 (888) OUR.AARP.

**The Inclusive Home Design Act** (H.R. 1408) was re-introduced to Congress by Rep. Jan Schakowsky (D-IL) in March 2009 and is supported by many members of Congress. For new homes built with federal assistance, the Act would supplement the existing required percentage of fully accessible units with visitability in all the other units. For the latest information on the bill's progress, please contact Rep. Schakowsky's Communications Director, Trevor Kincaid, at +1 (202) 226.6898.



Funding provided by the U.S. Department of Education,  
National Institute on Disability and Rehabilitation Research

---

Copyright 2009:



**Center for Inclusive Design &  
Environmental Access**  
378 Hayes Hall, University at Buffalo  
3435 Main Street  
Buffalo, NY 14214-3087

TEL: +1 (716) 829.3485 x 329  
TTY: +1 (716) 829.3758  
Fax: +1 (716) 829.3861  
Email: [idea@ap.buffalo.edu](mailto:idea@ap.buffalo.edu)  
Web: [www.ap.buffalo.edu/idea](http://www.ap.buffalo.edu/idea)